



VRLA Battery **SPHR 12-46W**

Specifications	Nominal Voltage	12 V				
	Rated Capacity (20 °C)	10min Rate (1,60V/cell)	15min Rate (1,60V/cell)	10hr Rate (1,80V/cell)	5hr Rate (1,70V/cell)	1hr Rate (1,60V/cell)
		46 W/cell	33,7 W/cell	7,8 Ah	7 Ah	5,89 Ah
	Dimensions (mm) & Weight (kg)	Length	Width	Height	Overall Height	Weight
		151mm	65mm	94mm	100mm	2,60 kg
	Number / Type of Terminals	2 / F6 (6.35mm)				

Technical Characteristics

Design Life at 20°C	5 years
Internal Resistance (Fully charged - 20 °C)	20 mΩ
Short-circuit current	600 A
Max Charging Current	3,2 A
Min safe end Discharge Voltage	1,60 V/cell
Self discharge per month at 20°C	3%
Recommended Charging Voltage at 20°C	Stand-by use (V/cell): 2,25 to 2,30 Cycle use (V/cell): 2,40 to 2,45
Container Material	ABS-UL94 HB
Electrolyte Type	Sulfuric Acid
Type of plates / Alloy	Flat plates / Lead-Calcium-Tin alloy
Type of Separator	Absorbant Glass Mat
Valve Type / Operational Pressure	Rubber / 1-3 psi (70-200 mbar)
Operating Temperature Range	-20 to +50°C
Storage time at 20°C	9 months

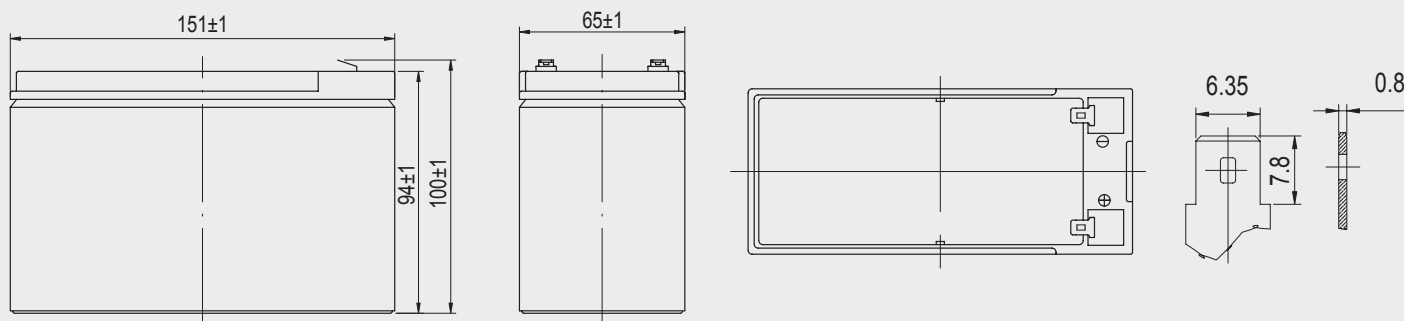

SYSTEMS SUNLIGHT S.A.

Headquarters

23rd klm. National Road Athens-Lamia
145 65 Ag. Stefanos Attica, Greece
Tel.: +30 210 6245400
Fax: +30 210 6245409

Manufacturing Plant

Neo Olvio
67 200 Xanthi, Greece
Tel.: +30 25410 48100
Fax: +30 25410 95446

 **SUNLIGHT**
creating energy

www.sunlight.gr